

Sedaconda® ACD Starter Kit

REF 2026040

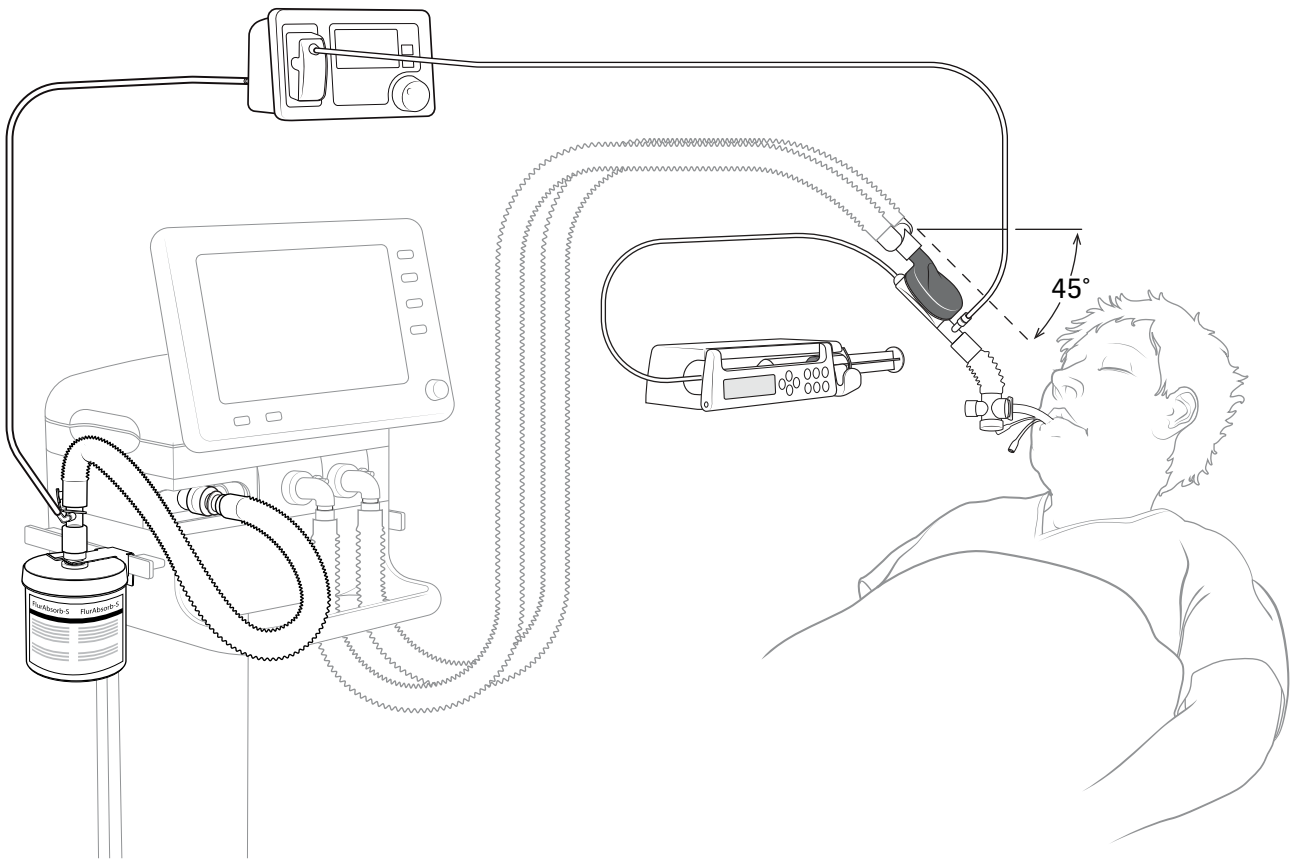

FlurAbsorb Set-up

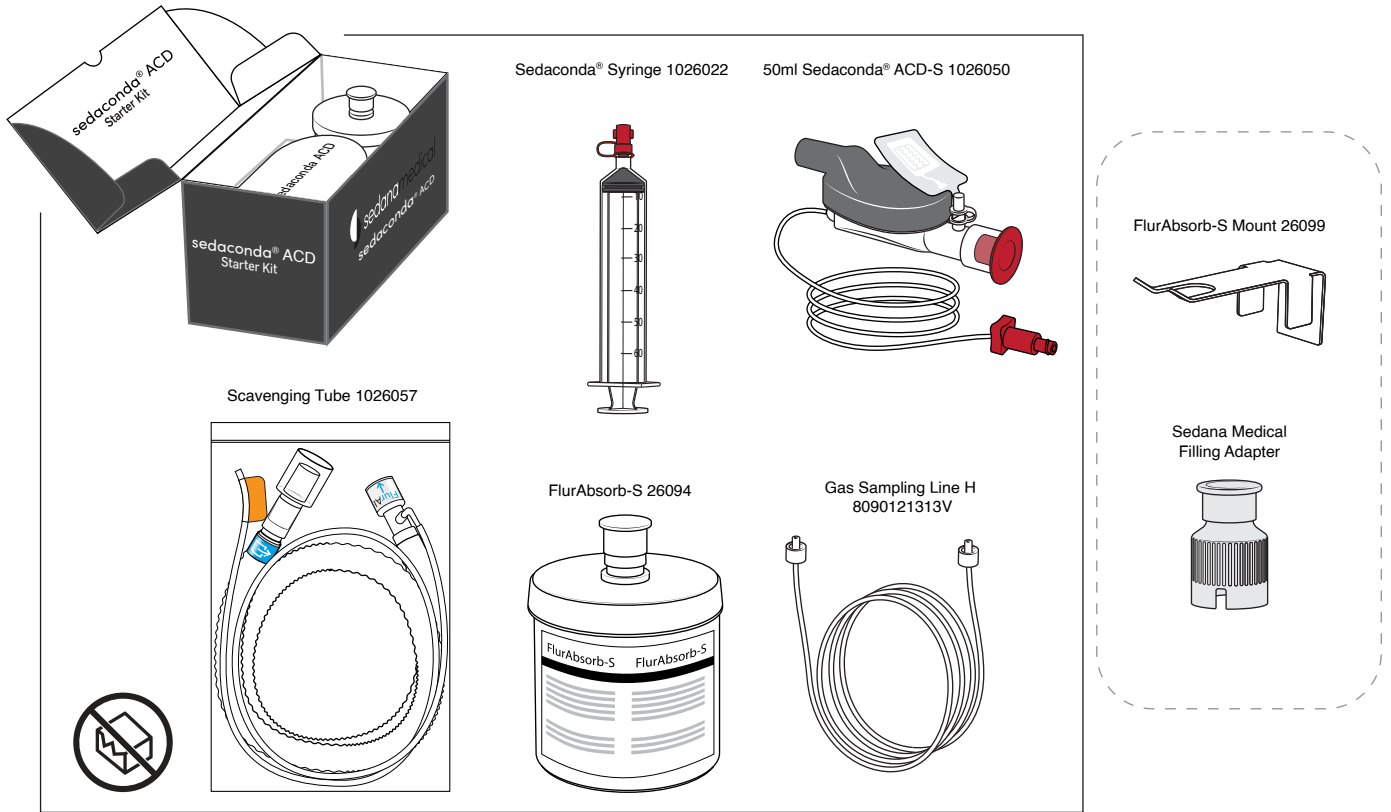
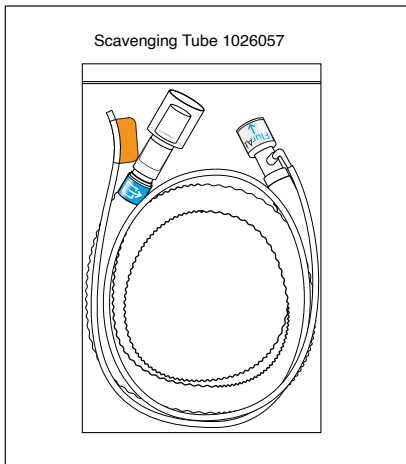

FlurAbsorb-S Mount 26099



FlurAbsorb-S 26094



1

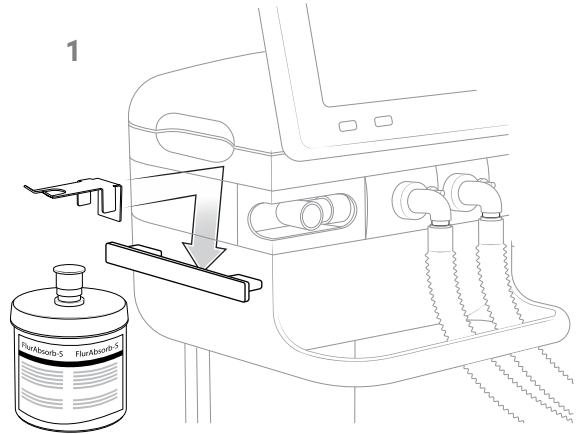

2

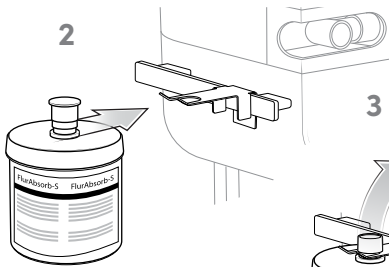

3



4

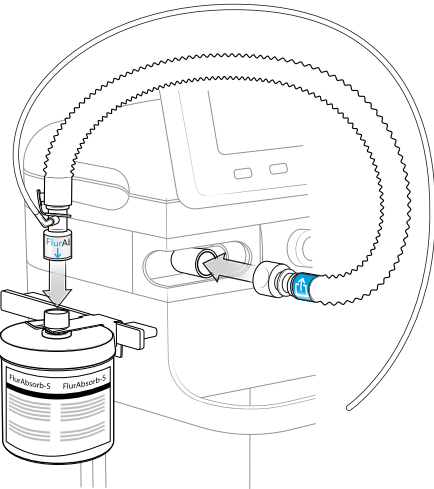

5

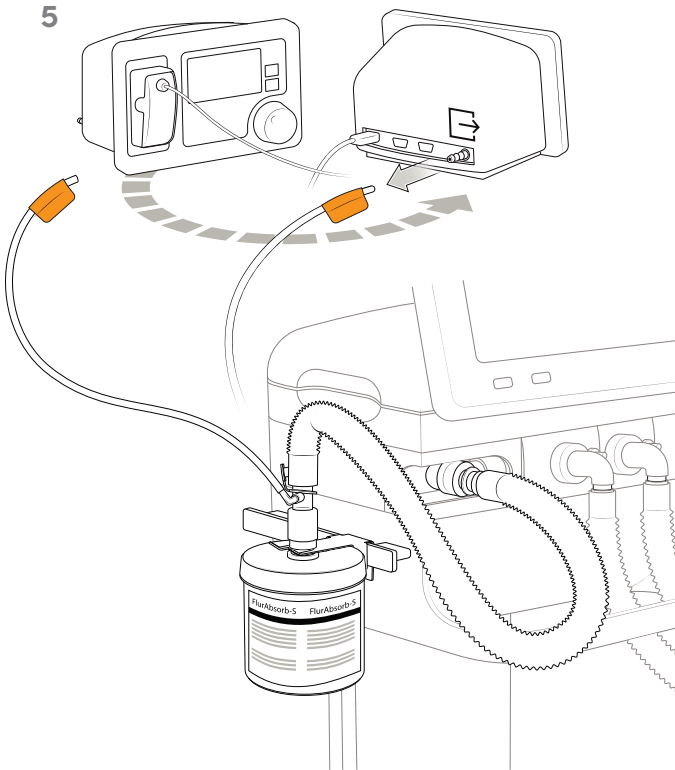

6

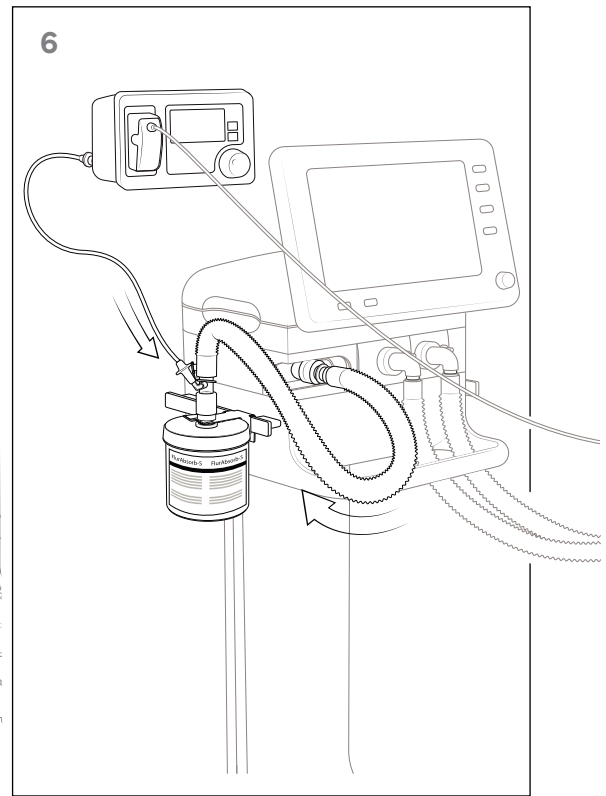

Anaesthetic Filling

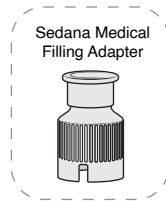
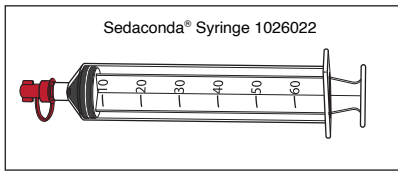

1



2



3



4

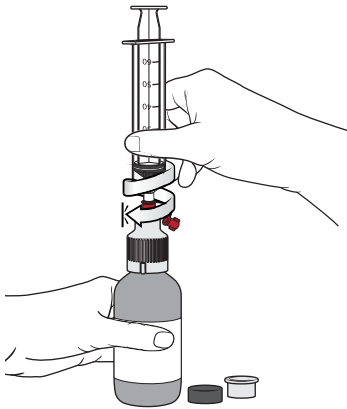

5

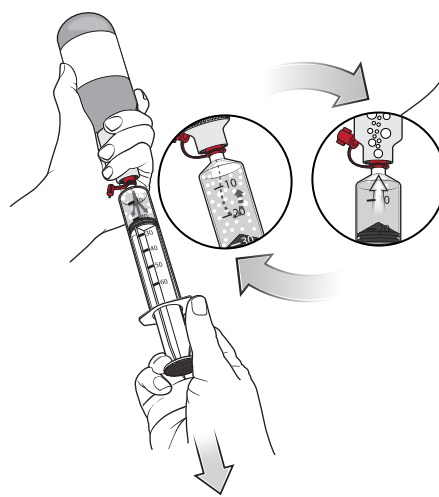

6

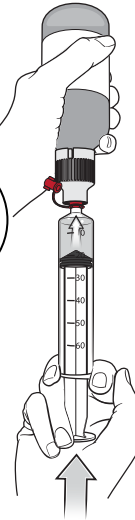

7

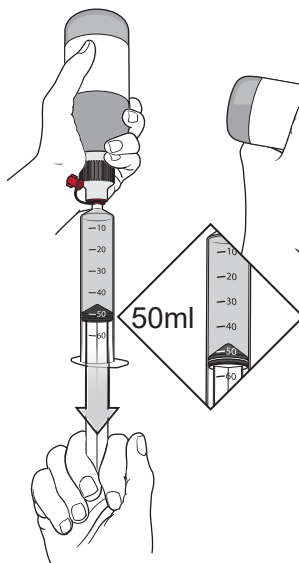

8

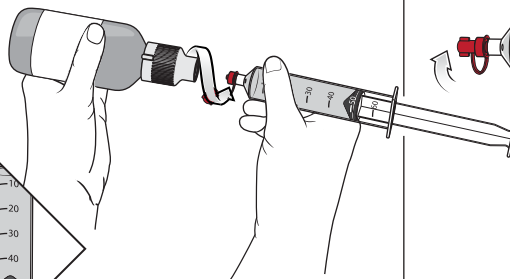

9

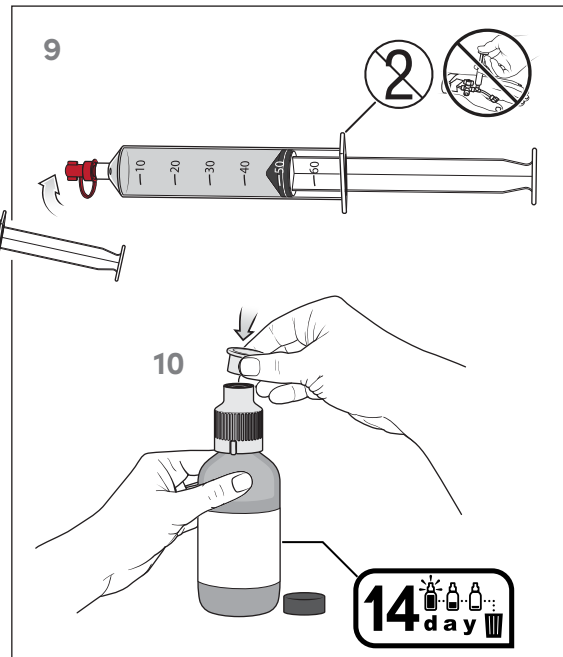

Sedaconda® ACD Set-up

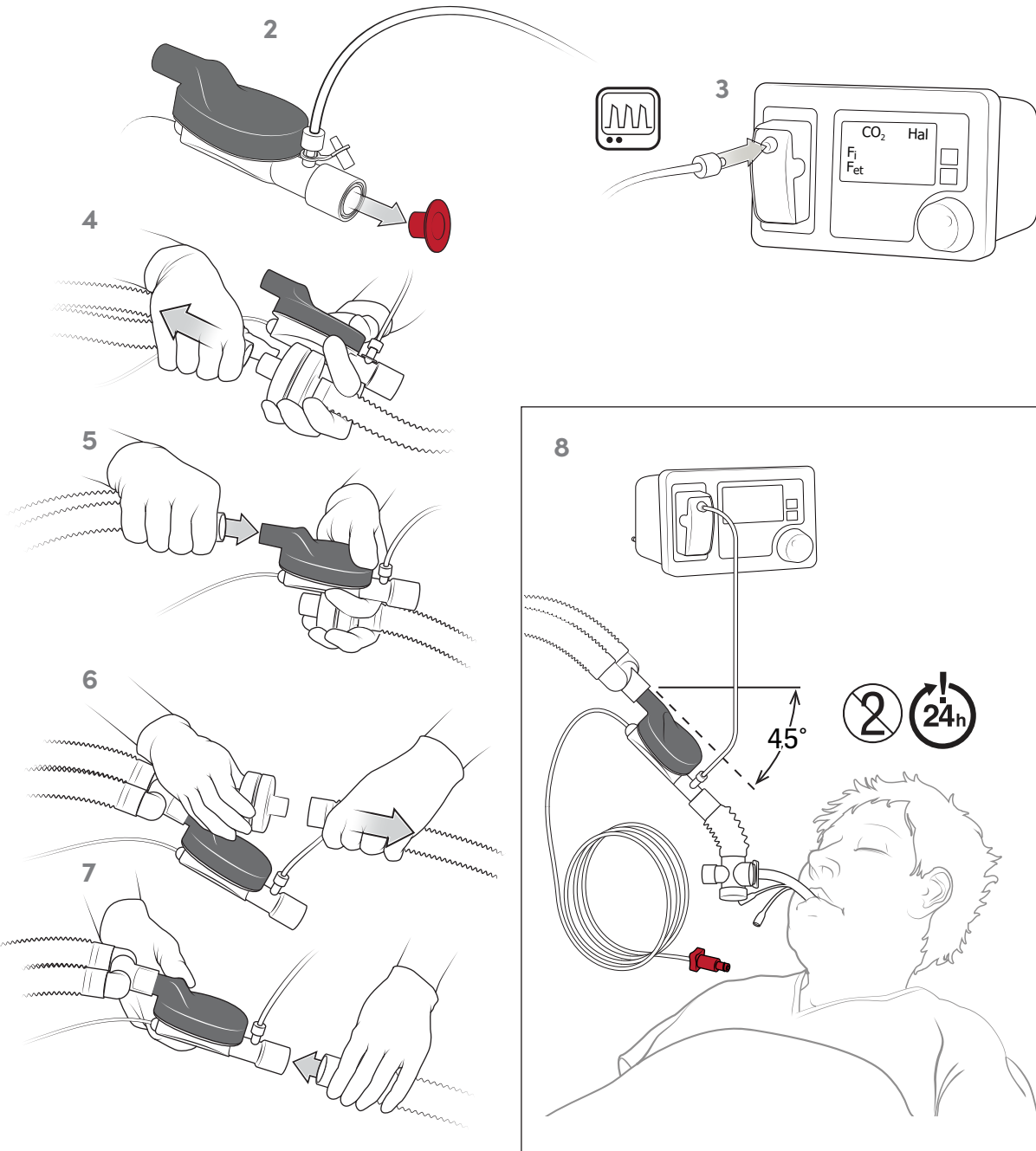
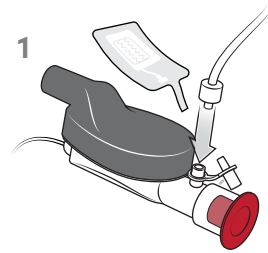
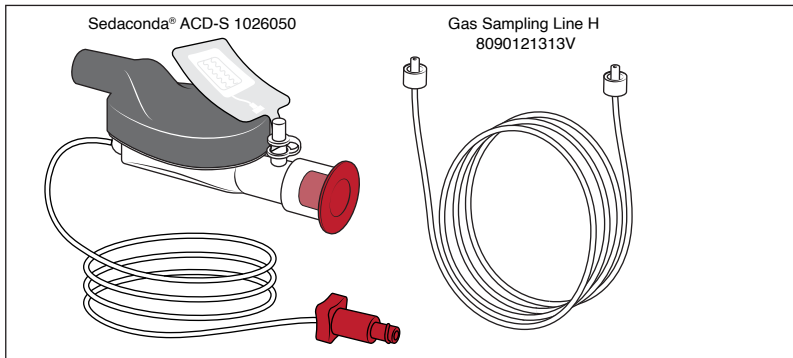

Syringe Pump Set-up

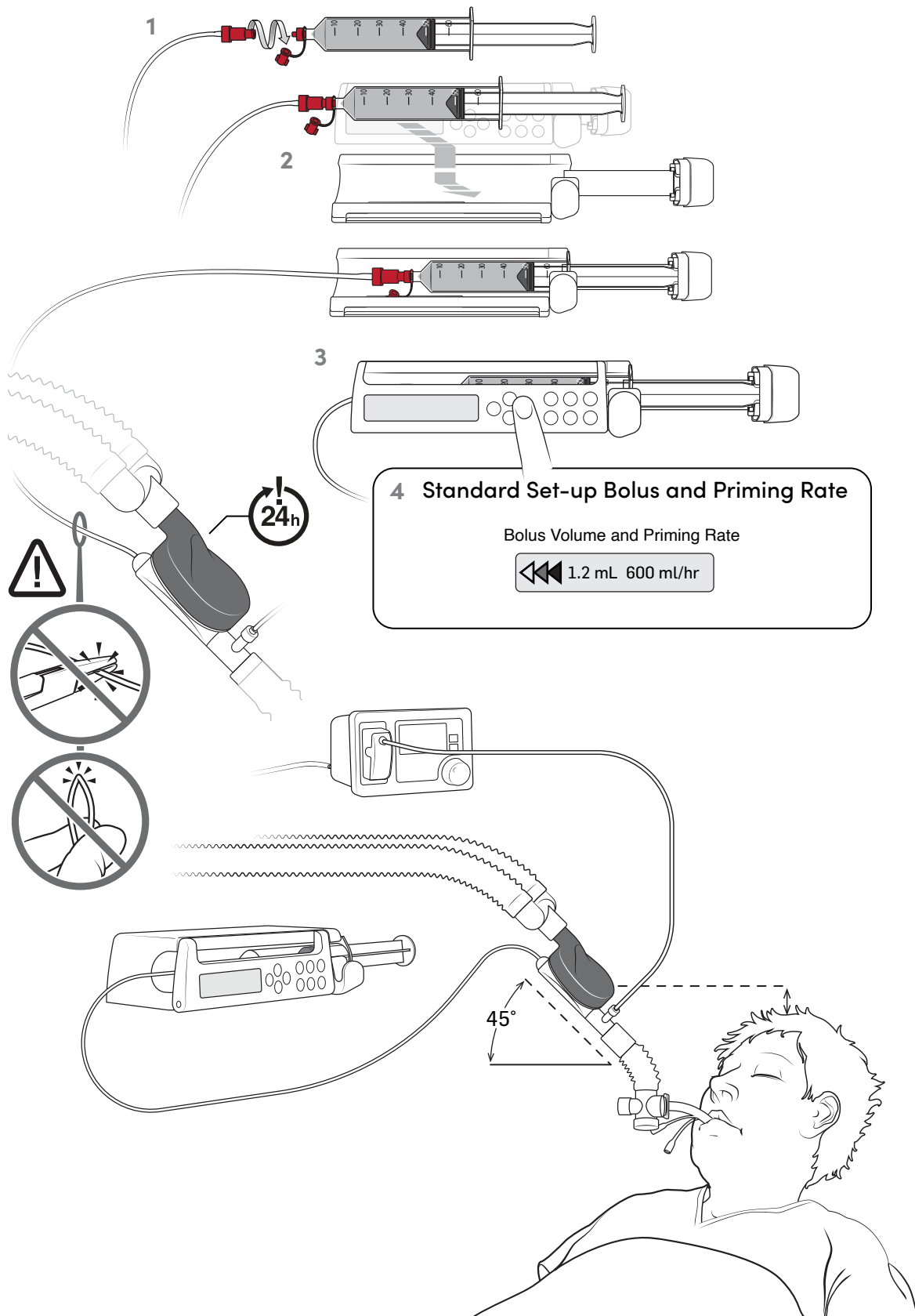



EN	Do not use if pack- age is damaged	Gas Monitor	Not for IV use	Change every 24 hours	Dispose of bottle and adapter within 14 days of application	In case of a serious incident please contact the competent authority and the legal manufac- turer Sedana Medical Ltd.
DE	Nicht verwenden, wenn Packung beschädigt ist	Gasmessgerät	Nicht zur intravenösen Anwendung	Alle 24 Stunden austauschen	Flasche und Adapter innerhalb von 14 Tagen nach Beginn der Anwendung entsorgen	Bei einem schwerwiegenden Vorfall verständigen Sie die zuständige Behörde und den Hersteller Sedana Medical Ltd.
FR	Ne pas utiliser si l'emballage est endommagé	Dispositif de mesure de gaz	Pas destiné à une utilisation intraveineuse	Changer toutes les 24 heures	Mettre au rebut le flacon et l'adaptateur dans les 14 jours suivant l'utilisation	En cas d'incident grave, veuillez contacter l'autorité compétente et le fabricant légal, Sedana Medical Ltd.
ES	No utilizar si el paquete está dañado	Dispositivo de medición de gas	No apto para uso IV	Sustituir cada 24 horas	Deseche el frasco y el adaptador en un plazo de 14 días desde la aplicación	En caso de un accidente grave, póngase en contacto con la autoridad competente y con el fabricante legal Sedana Medical Ltd.
IT	Non utilizzare se la confezione è danneggiata	Dispositivo di misurazione gas	Non per uso endovenoso	Sostituire ogni 24 ore	Smaltire il flacone e l'adattatore entro 14 giorni dall'applicazione	In caso di incidente grave, contattare l'autorità competente e il fabbricante legale Sedana Medical Ltd.
SV	Använd inte om förpackningen är skadad	Gasmätare	Ej avsedd för intravenös behandling	Byt ut enheten en gång	Kassera flaskan och adaptern inom 14 dagar efter applicering	I händelse av en allvarlig incident, kontakta behörig myndighet och tillverkaren Sedana Medical Ltd.
NO	Må ikke brukes hvis pakningen er skadet	Gassmålingsinstrument	Ikke for bruk med IV	Bytt ut én gang i døgnet.	Kast flasken og adapteren innen 14 dagers bruk	I tilfelle en alvorlig hendelse, ta kontakt med kompetent myndighet og den juridiske produsenten Sedana Medical Ltd.
DA	Må ikke anvendes, hvis pakningen er beskadiget	Gasmåleenhed	Må ikke anvendes intravenøst	Udskiftes hvert døgn	Bortskaf beholderen og adapteren inden for 14 dage efter anvendelse	I tilfælde af en alvorlig ulykke kontaktes den kompetente myndighed samt den lovmæssige producent Sedana Medical Ltd.
FI	Ei saa käyttää, jos pakkaus on vaurioitunut	Kaasunmittauslaite	Ei suomenlaiseseen käyttöön	Vaihda 24 tunnin välein	Hävitä pullo ja sovitin 14 päivän kuluessa käytön aloittamisesta	Vakavista vaaratilanteista on ilmoitettava toimivaltaiselle viranomaiselle ja lailliselle valmistajalle Sedana Medical Ltd:lle
EL	Μην χρησιμοποιείτε το προϊόν εάν η συσκευασία έχει υποστεί ζημιά	Συσκευή μέτρησης αερίου	Δεν είναι κατάλληλο για ενδοφλέβια χρήση	Αλλαγή ανά 24 ώρες	Απορρίψτε τη φιάλη και τον προσαρμογέα εντός 14 ημερών από την εφαρμογή	Σε περίπτωση σοβαρού συμβάντος επικοινωνήστε με την αρμόδια αρχή και τον νόμιμο κατασκευαστή Sedana Medical Ltd.
NL	Niet gebruiken indien de verpakking beschadigd is	Gasmeethulpmiddel	Niet voor IV-gebruik	Om de 24 uur vervangen	Gooi fles en adapter weg binnen 14 dagen na gebruik	Neem in geval van een ernstig incident contact op met de bevoegde autoriteit en met de wettelijke fabrikant Sedana Medical Ltd.
PL	Nie używać, jeśli pakowanie jest uszkodzone	Miernik gazu	Nie nadaje się do podawania dożylnego	Zmieniać co 24 godziny	Wyrzucić butelkę i adapter po upływie 14 dni od pierwszego użycia	W razie wystąpienia poważnego incydentu prosimy o kontakt z właściwym organem i producentem prawnym, tj. firmą Sedana Medical Ltd
PT	Não use se a embalagem estiver danificada	Dispositivo de medição de gás	Não indicado para uso IV	Trocar a cada 24 horas	Descarte o frasco e o adaptador 14 dias após o início da aplicação	AVISO! Repetidas nebulizações poderão aumentar a resistência do fluxo do AnaConDa. Preste atenção a sinais de oclusão.
RU	Не используйте, если упаковка повреждена	Газоизмерительное устройство	Изделие не предназначено для внутривенного использования	Заменять каждые 24 часа	Используйте открытый флакон с адаптером в течение 14 дней	В случае серьезного инцидента обратитесь в компетентный орган и к официальному производителю Sedana Medical Ltd.
EE	Mitte kasutada, kui pakend on kahjustatud	Gaasi mõõtmise seade	Ei ole mõeldud i.v. kasutamiseks	Vahetage iga 24 tunni järel	Visake pudel ja adapter ära 14 päeva jooksul pärast kasutamise alustamist	Tõsise juhtumi korral võtke ühendust pädeva asutuse ja seadusliku tootjaga Sedana Medical Ltd.





SL	Ne uporabljajte, če je embalaža poškodovana	Pripomoček za merjenje plinov	Ni za iv. uporabo	Zamenjajte vsakih 24 ur	Steklenico in nastavek zavržite najpozneje 14 dni po odprtju	V primeru resnega incidenta se obrnite na pristojni organ in pravnega proizvajalca izdelka, družbo Sedana Medical Ltd.
CZ	Nepoužívejte, pokud je balení poškozené	Zařízení na měření plynů	Nepoužívejte k i.v. aplikaci.	Výměna každých 24 hodin	Láhev a adaptér zlikvidujte do 14 dnů od zahájení aplikace	V případě vážného incidentu kontaktujte příslušný úřad a legálního výrobce, společnost Sedana Medical Ltd.
SK	Nepoužívajte, ak je obal poškodený	Pomôcka na meranie plynu	Nepoužívať na aplikáciu infúzie	Vymeniť každých 24 hodín	Fľašu a adaptér zlikvidujte do 14 dní od použitia	V prípade závažného incidentu kontaktujte príslušný orgán a zákonného výrobcu Sedana Medical Ltd.
TR	Ambalaj hasar görmüşse kullanmayın	Gaz Ölçüm Cihazı	IV kullanımı için uygun değildir	Her 24 Saatte Bir Değiştirin	Şişeyi ve adaptörü kullandıktan sonraki 14 gün içinde atın	Ciddi bir kaza durumunda lütfen yetkili makamlara ve yasal üretici Sedana Medical Ltd. ile iletişime geçin.
HR	Nemojte upotrijebiti ako je pakiranje oštećeno	Uređaj za mjerenje plina	Nije za IV uporabu	Zamijeniti svaka 24 sata	Bočicu i adapter odložite u otpad u roku od 14 dana od početka primjene	U slučaju ozbiljnog incidenta obratite se nadležnom organu i legalnom proizvođaču tvrtke Sedana Medical Ltd.
HU	Ne használja, ha sérült a csomagolás	Gázarámíásmérő készülék	Nem intravénás használatra	24 óránként cserélje ki	A flakont és az adaptert a felhasználástól számított 14 napon belül dobja ki	Súlyos incidens esetén forduljon az illetékes hatósághoz és a Sedana Medical Ltd. törvényes gyártójához
SR	Nemojte koristiti ako je pakovanje oštećeno	Uređaj za merenje gasa	Nije za IV upotrebu	Zamenite na svakih 24 sata	Odložite bočicu i adapter u roku od 14 dana od upotrebe	U slučaju ozbiljnog incidenta, obratite se nadležnom organu i proizvođaču Sedana Medical Ltd.
BG	Да не се използва при повреда на опаковката	Измервателно устройство за газ	Не е за i.v. приложение	Да се сменя на всеки 24 часа	Медицинско изделие	В случай на сериозна злоупотрека се свържете с компетентния орган и с официалния производител Sedana Medical Ltd.
RO	Nu utilizați dacă pachetul este deteriorat	Dispozitiv de măsurare a gazului	Nu se folosește intravenos	A se înlocui la fiecare 24 de ore	Aruncați flaconul și adaptorul în cel mult 14 de zile de la prima aplicare	În cazul apariției unui incident grav, contactați autoritatea competentă și producătorul legal Sedana Medical Ltd.
AR	هم ادخستسا بآن جت ةوبعلا تناك ذإ ةفالات	زاغلا سايق زاغ	صصخم ريغ يدي رولا مادخستسالل	ةعاس 24 لك لدببستسي	وي اهملا او ةجاجزلا نم صلخنت لوأ نم أموي 14 نوضنغ يف مادخستسا	Sedana Medical Ltd. ري طخ شداح عوقو ةلاح يف ةظلسلاب لاصتالا يجرى ةعنصلما ةكشرشلا او قصتخملما ةينوناقلا
KO	포장이 훼손된 경우에는 사용하지 않습니다.	가스 측정 기기	정맥주사용 아님	24시간마다 교체하십시오.	의료 기기	심각한 사고가 발생한 경우, 관계기관 및 Sedana Medical Ltd. 의 법적 제조사에 문의하십시오.
JP	包装が破損している場合は使用しないでください	ガス測定装置	静注用ではありません	24 時間ごとに交換してください	医療機器	重大な事故が発生した場合には、所轄官庁および legal manufacturer である Sedana Medical Ltd. までご連絡ください。
ZH	如果包装损坏, 请勿使用	气体测量装置	不适用于静脉给药	每 24 小时更换一次	医疗设备	如果出现严重事故, 请联系主管当局和合法生产商 Sedana Medical Ltd.

